

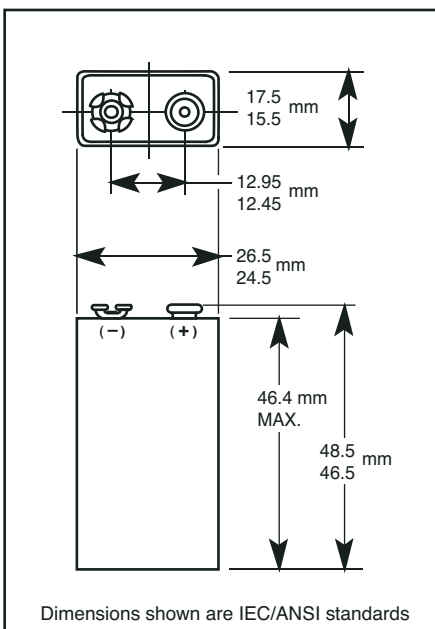

<b>Nominal Voltage:</b>	9 V
<b>Operating Voltage:</b>	9.6 - 4.8 V
<b>Impedance:</b>	1,700 m-ohm @ 1kHz
<b>Typical Weight:</b>	45 gm (1.6 oz.)
<b>Typical Volume:</b>	22.8 cm <sup>3</sup> (1.4 in. <sup>3</sup> )
<b>Terminals:</b>	Miniature Snap
<b>Storage Temperature Range:</b>	-20 <sup>o</sup> C to 35 <sup>o</sup> C
<b>Operating Temperature Range:</b>	-20 <sup>o</sup> C to 54 <sup>o</sup> C (-4 <sup>o</sup> F to 130 <sup>o</sup> F)
<b>ANSI:</b>	1604A
<b>IEC:</b>	6LR61

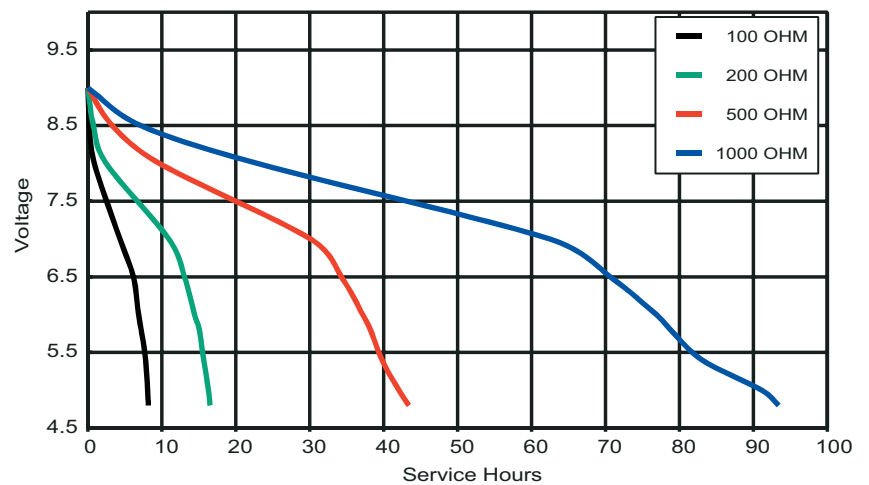

TYPICAL DISCHARGE CHARACTERISTICS AT 21°C (70°F)



## DURACELL® BATTERIES

Berkshire Corporate Park  
Bethel, CT 06801 U.S.A.  
Telephone: Toll-free 1-800-544-5454  
Internet: www.duracell.com

\* Delivered capacity is dependent on the applied load, operating temperature and cut-off voltage. Please refer to the charts and discharge data shown for examples of the energy / service life that the battery will provide for various load conditions.

TYPICAL CONSTANT CURRENT DISCHARGE CHARACTERISTICS AT 21°C (70°F)

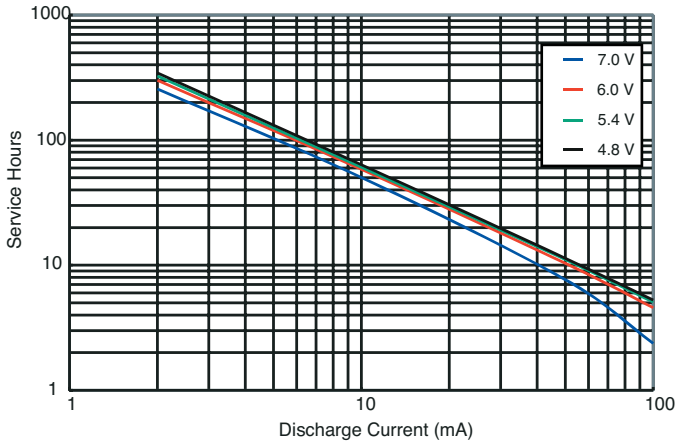

TYPICAL DISCHARGE CHARACTERISTICS AT 21°C (70°F)

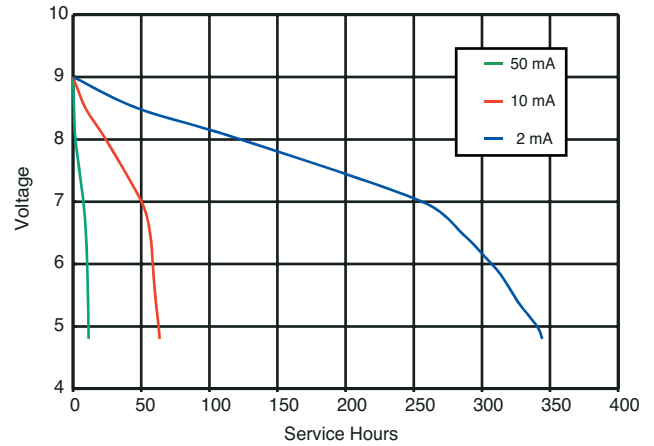

TYPICAL DISCHARGE CHARACTERISTICS AT 21°C (70°F)

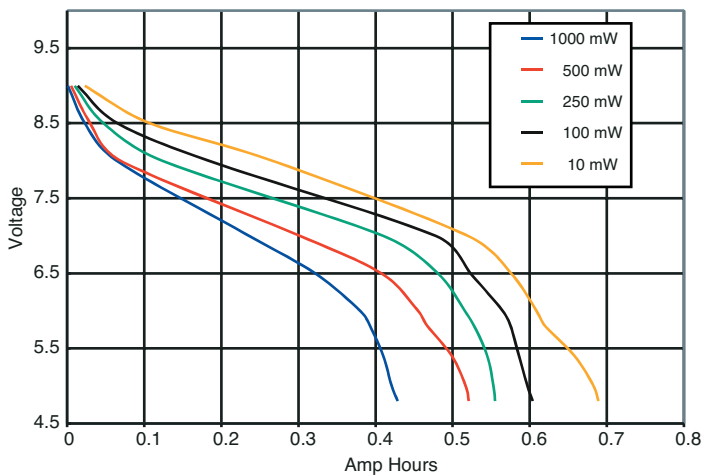

TYPICAL TOY TEST AT 21°C AND 0°C

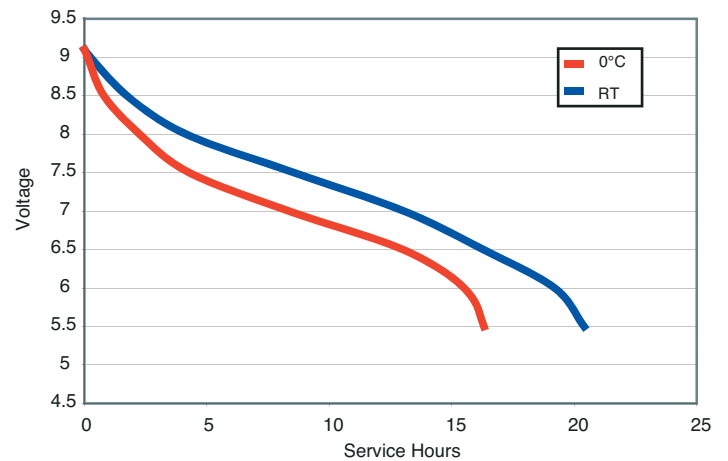

# DURACELL<sup>®</sup>

BATTERIES

Berkshire Corporate Park  
Bethel, CT 06801 U.S.A.  
Telephone: Toll-free 1-800-544-5454  
Internet: [www.duracell.com](http://www.duracell.com)

\* Delivered capacity is dependent on the applied load, operating temperature and cut-off voltage. Please refer to the charts and discharge data shown for examples of the energy / service life that the battery will provide for various load conditions.